

DS dynatec : Vérin rotatif/ Rotary actuator

Groupe TXCOM - DS dynatec, 10 avenue Descartes, 92 350 Le Plessis Robinson- www.ds-dynatec.com

Type: Hydraulique à palette(s)/ Hydraulic vane
Produit/ product: HPSD 1015 / HPSD 1018

Caractéristiques générales Characteristics

Fluide/ fluid:

Huile minérale ou pneumatique/ Mineral oil or pneumatic

Pression nominale d'utilisation/ nominal operating pressure: 50 bar

Pression maximal de service/Max. operating pressure: 70 bar

Pression de décollement/ Breakaway pressure : 2 bar

Couple/ Torque at 50 bar : 6Nm

Fuite interne / Internal leakage :

10ml/min @50bar

Clindrée / Displacement :

0.027cm³/°

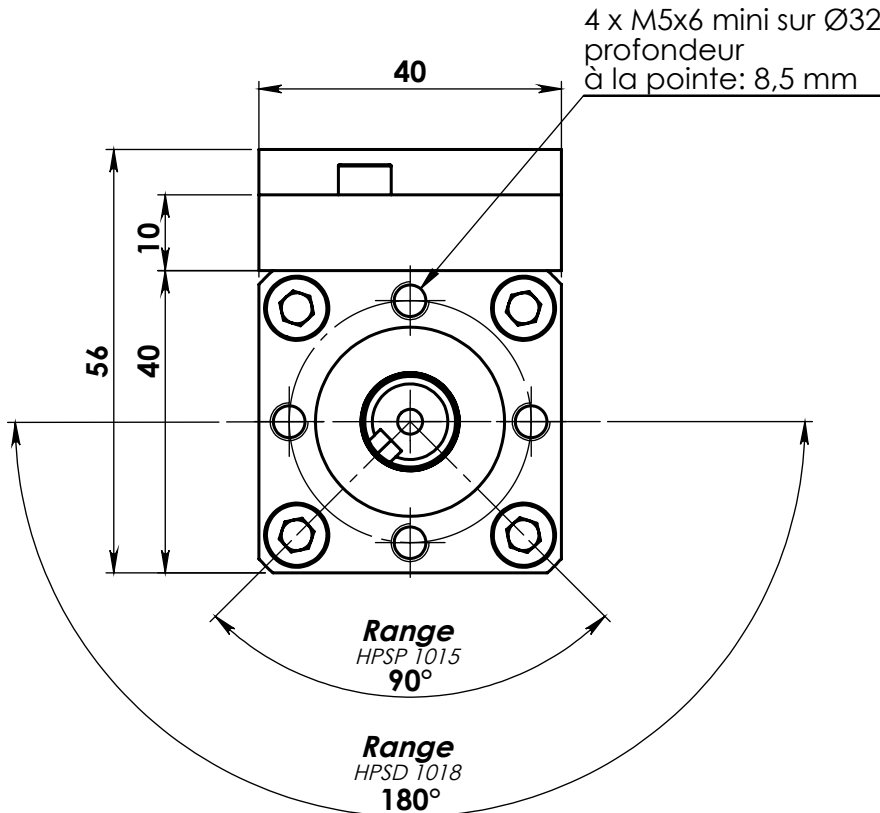

	HPSD 1015 HPSD 101-90°	HPSD 1018 HPSD 101-180°
Rotation	90°	180°
Masse / Weight		
Manifold Vertical	0,68 kg	0,66 kg
Manifold Horizontal	0,71 kg	0,69 kg

Temp. d'utilisation/

Temp. of use: -10°C/+70°C

Arbre/ Shaft: Acier/ Steel

Corps/ Body: Acier/ Steel

Flasque/ Flanges: Aluminium anodisé dur/ Hard anodized aluminium

Joint/ Seals nitrile ou/ or viton (à définir/ to define)

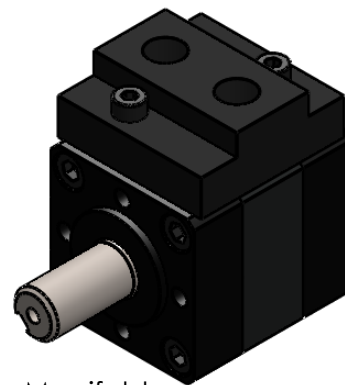
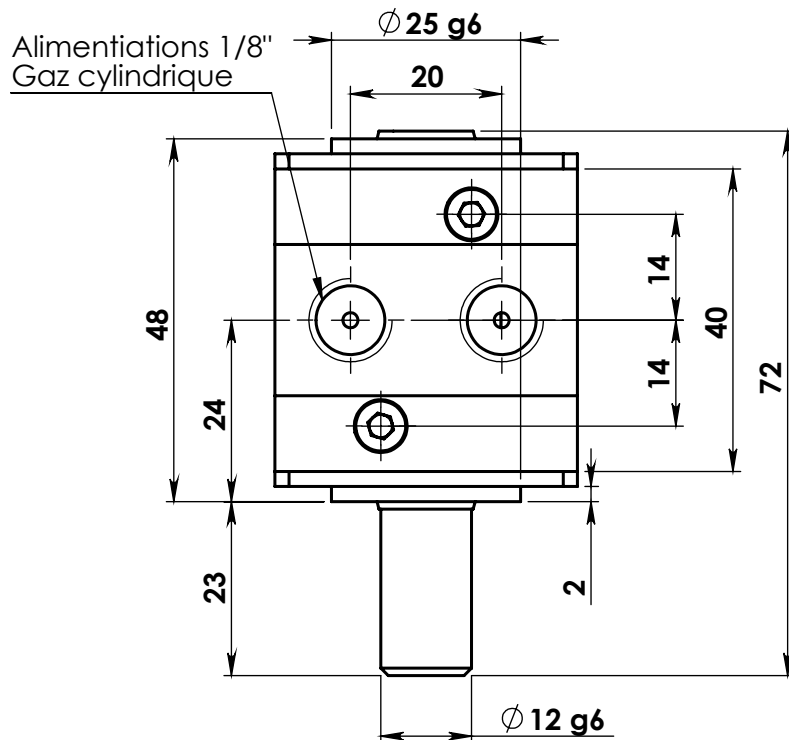

Manifold Vertical

Modèle CAO disponible sur demande.

CAO model available on request.

© Groupe TXCOM- Tout droits réservés - All rights reserved

Proprietary and confidential information of TXCOM group. Reproduction and use are limited under applicable non-disclosure and non-use terms and conditions. All copies remain the property of TXCOM group.